

12V DC Water Pump with Brushless Motor DC40-1245

950mA Current & 4.5m Water Height

11.5W & 550L/H

* Features :

- Super long working life(more than 30000 hours)
- Adopt high performance ceramic shaft
- Amphibious design
- Submersible installation and entirely waterproof
- low consumption
- low noise(less than35db)



Copyright © 2002-2011 SAVEBASE®. All rights reserved.

* Descriptions:

This product can be used in many fields, such as computer cooling system, Garden fountain, Aquarium, car cooling system, humidifier, air conditioner, and many other cooling and circulation systems.

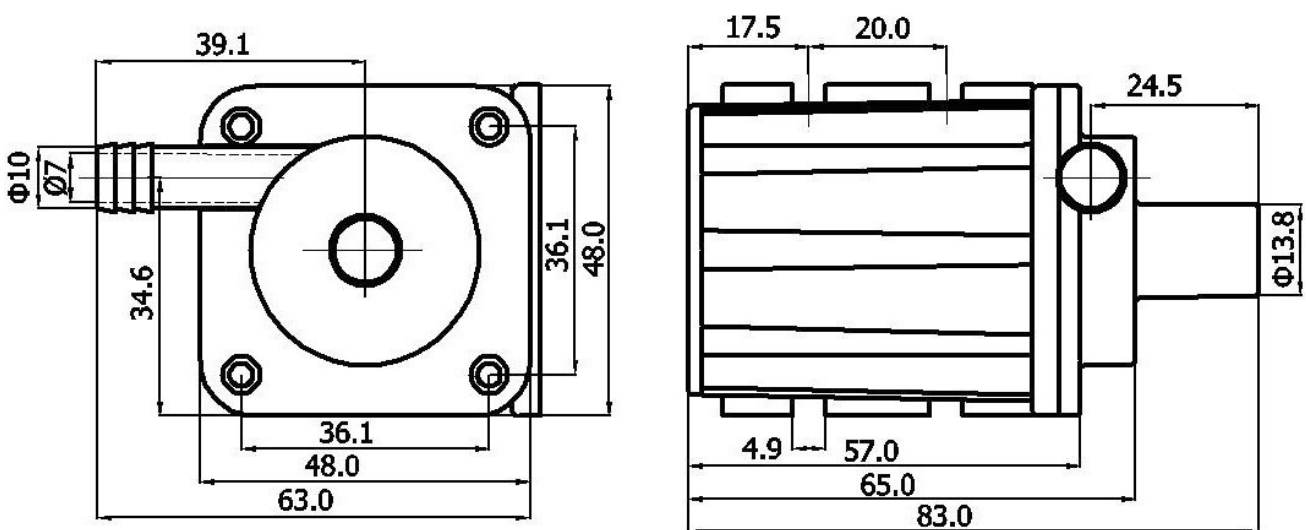

*DC40 Series:

We have a wide range of water pumps with different specifications, please find the following list of all DC40 Series for your reference:

Model	Voltage(V)	Current(mA)	Head(m)	Flow(L/H) at zero head	Power(w)
DC40-0510	5	500	1	250	2.5
DC40-0615	6	600	1.5	300	3.6
DC40-0920	9	450	2	320	4
DC40-0925	9	550	2.5	360	5
DC40-0930	9	650	3	380	6
DC40-0935	9	870	3.5	420	8
DC40-1220	12	360	2	320	4.5
DC40-1225	12	450	2.5	350	5.5
DC40-1230	12	560	3	380	6.8
DC40-1235	12	650	3.5	420	8
DC40-1240	12	840	4	460	10
DC40-1245	12	950	4.5	480	11.5
DC40-1250	12	1000	5	500	12
DC40-2430	24	350	3	400	8.4
DC40-2435	24	450	3.5	450	10.8
DC40-2440	24	550	4	480	13.2
DC40-2445	24	600	4.5	510	14.4
DC40-2450	24	650	5	560	15.6
DC40-2455	24	700	5.5	580	16.8
DC40-2460	24	800	6	600	19.2
DC40-2465	24	950	6.5	630	22.8
DC40-2470	24	1100	7	650	26.4

Note: Maximum liquid temperature: 60°C, 172F

Head-Flow Curve Graph:

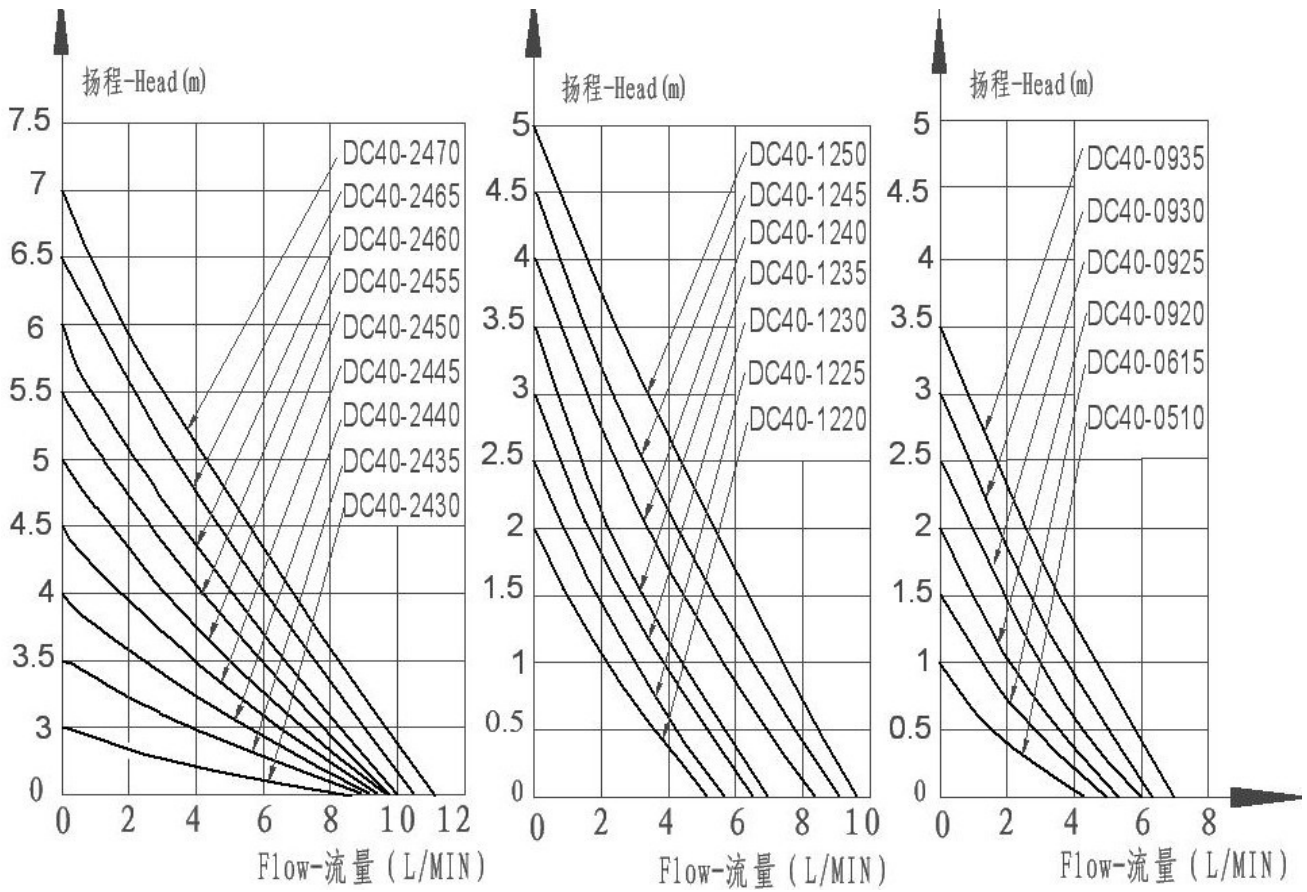

Model number DC40-1245 Max operating Temp 60°C, 172F Voltage 12V Noise Less than 35db Power cord 1.0M(bared) Dimension 86×63×48mm Weight approx. 220g